



EMC TEST REPORT

Radio Frequency Devices - Unintentional Radiators

Test Report No.:	TCT211130E019	
Date of issue	Jan. 06, 2022	
Testing laboratory.....:	SHENZHEN TONGCE TESTING LAB	
Testing location/ address.....:	TCT Testing Industrial Park Fuiqiao 5th Industrial Zone, Fuhai Street, Bao'an District Shenzhen, Guangdong, 518103, People's Republic of China	
Applicant's name	NEMO POWER TOOLS LIMITED	
Address.....:	21st Floor, CMA Building 64 Connaught Road Central Hong Kong, PRC	
Manufacturer's name	Nemo Power Tools (Huizhou) Co., Ltd.	
Address.....:	2/F, 4 th Industrial Area, Luokeng Village, Xiaotie, Zone, Xiaojinkou Town, Huicheng District, Huizhou City, Guangdong Province, China, 516023	
Standard(s)	FCC 47 CFR Part 15 Subpart B	
Test item description.....:	GRABO PRO	
Trade Mark.....:	GRABO	
Model/Type reference	GP-1Li-FB-1S, GP-1Li-FB-1S-JP, GP-1Li-HC-2S-P, NG-Pro-14.8-2Li, GP-1Li-FB-1S-HC	
Rating(s)	Input: DC 14.8 V, 2.6 A Power Supply Model: XVE024-1680140 Power Supply Input: AC 100-240 V, 50/ 60 Hz, 0.7 A Max Power Supply Output: DC 16.8 V, 1.4 A	
Date of receipt of test item.....:	Nov. 30, 2021	
Date (s) of performance of test:	Nov. 30, 2021 ~ Jan. 06, 2022	
Tested by (+signature).....:	Kyle ZHOU	
Check by (+signature)	Howie LYU	
Approved by (+signature)	Tomsin	

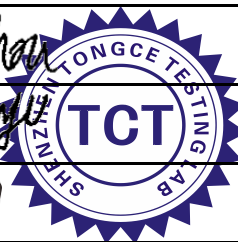

General disclaimer:

This report shall not be reproduced except in full, without the written approval of SHENZHEN TONGCE TESTING LAB This document may be altered or revised by SHENZHEN TONGCE TESTING LAB personnel only, and shall be noted in the revision section of the document. The test results in the report only apply to the tested sample.

Table of Contents

1. General Product Information	3
1.1. EUT description	3
1.2. Model(s) list	3
2. Test Information	4
2.1. EUT operation mode(s)	4
2.2. Special accessories and auxiliary equipment	4
2.3. Configuration of system under test	4
2.4. General test conditions	5
3. Test Result Summary	6
4. List of Test Equipment	7
5. Test Conditions and Results	8
5.1. Disturbance voltage at mains terminals	8
5.2. Radiated emission	11
6. Test set-up photo	14
7. Photo of the EUT	15

1. General Product Information

1.1.EUT description

Test item description	GRABO PRO
Model/Type reference	GP-1Li-FB-1S
Rating(s)	Input: DC 14.8 V, 2.6 A Power Supply Model: XVE024-1680140 Power Supply Input: AC 100-240 V, 50/ 60 Hz, 0.7 A Max Power Supply Output: DC 16.8 V, 1.4 A
Highest internal frequency F_x	<input checked="" type="checkbox"/> $F_x \leq 108$ MHz <input type="checkbox"/> 108 MHz $< F_x \leq 500$ MHz <input type="checkbox"/> 500 MHz $< F_x \leq 1$ GHz <input type="checkbox"/> $F_x > 1$ GHz_
DC Line	<input type="checkbox"/> Shielded <input checked="" type="checkbox"/> Unshielded <input checked="" type="checkbox"/> Detachable <input type="checkbox"/> Un-detachable <input type="checkbox"/> No applicable <input checked="" type="checkbox"/> Length: 1.5 m
AC Line	<input type="checkbox"/> Shielded <input type="checkbox"/> Unshielded <input type="checkbox"/> Detachable <input type="checkbox"/> Un-detachable <input checked="" type="checkbox"/> No applicable <input type="checkbox"/> Length:

1.2.Model(s) list

No.	Model No.	Tested with
1	GP-1Li-FB-1S	<input checked="" type="checkbox"/>
Other models	GP-1Li-FB-1S-JP, GP-1Li-HC-2S-P, NG-Pro-14.8-2Li, GP-1Li-FB-1S-HC	<input type="checkbox"/>

Note: GP-1Li-FB-1S is tested model, other models are derivative models. The models are identical in circuit and PCB layout, only different on the model names, and the number of batteries, sealing rings and cloth bags. So the test data of GP-1Li-FB-1S can represent the remaining models.

2. Test Information

2.1.EUT operation mode(s)

Mode #	Operating mode description	Test voltage
1	Charging	AC 120 V/ 60 Hz
2	Working	DC 14.8 V

Test worst operating mode	
Radiated emission	Mode 2
Remark: The worst measurement data and graphical presentation show in this report.	

2.2.Special accessories and auxiliary equipment

Product Type	Manufacturer	Model No.	Serial No.
/	/	/	/

2.3.Configuration of system under test

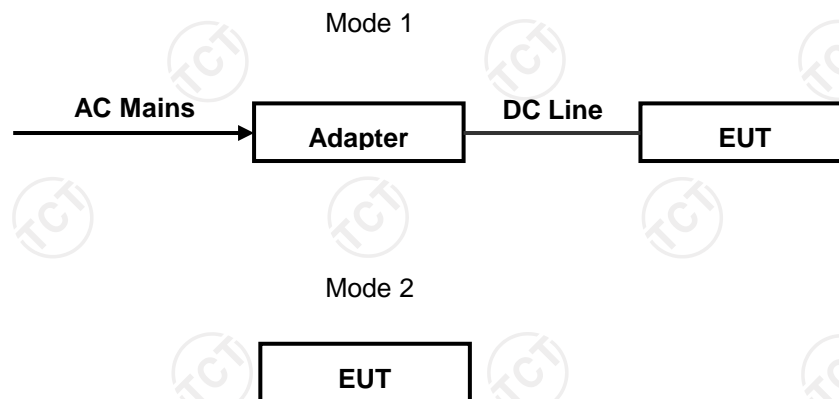

(EUT: GRABO PRO)

2.4. General test conditions

Environmental reference conditions

The climatic conditions during the tests are within the limits specified by the manufacturer for the operation of the EUT and the test equipment.

The climatic conditions during the tests were within the following limits:

Temperature	Humidity	Atmospheric pressure
15 °C – 35 °C	30 % - 60 %	86 kPa – 106 kPa

If explicitly required in the basic standard or applied product standard the climatic values are recorded and documented separately in this test report.

Measurement uncertainties

Test Item	Uncertainty
Uncertainty for Disturbance voltage at the mains terminals	3.10 dB
Uncertainty for Radiated emission (30 MHz to 1 GHz)	4.56 dB
Uncertainty for Radiated emission (above 1 GHz)	4.22 dB

The overall measurement uncertainty of a measurement is defined as the range of which can be supposed that it contains the true value with a specified probability.

This probability is 95 % for the generally specified measurement uncertainty (so-called expanded measurement uncertainty).

The limits for emission measurements and the Test levels for immunity tests in the applied standards were defined taking into consideration the accuracy limits for measurement and testing equipment required by the Basic standards.

All measurement and test results of the EMC laboratory of SHENZHEN TONGCE TESTING LAB fulfil the requirements for measurement uncertainties according to the standards applied.

Decision rule for statement(s) of conformity is based on accuracy method specified in Clause 4.4.3 in IEC Guide 115:2021.

3. Test Result Summary

FCC 47 CFR Part 15 Subpart B	
Requirement – Test case	Verdict
Classification Class (<input type="checkbox"/> A <input checked="" type="checkbox"/> B)	—
Disturbance voltage at the mains terminals	Pass
Radiated emission	Pass
Remark:---	

Test case verdicts	
- Test case does not apply to the test object	N/A
- Test object does meet the requirement.....	P (Pass)
- Test object does not meet the requirement	F (Fail)

4. List of Test Equipment

Equipment	Manufacturer	Model No.	Serial No.	Cal. Due
Disturbance voltage at mains terminals				
EMI Test Receiver	R&S	ESCI3	100898	2022/07/07
LISN	Schwarzbeck	NSLK 8126	8126453	2022/03/11
Attenuator	N/A	10 dB	164080	2022/07/07
Radiated emission (30 MHz to 1 GHz)				
Broadband Antenna	Schwarzbeck	VULB9163	340	2022/09/04
EMI Test Receiver	R&S	ESIB7	100197	2022/07/07
Pre-amplifier	HP	8447D	2727A05017	2022/07/07
Radiated emission (above 1 GHz)				
Horn Antenna	Schwarzbeck	BBHA 9120 D	02372	2023/03/06
EMI Test Receiver	R&S	ESIB7	100197	2022/07/07
Pre-amplifier	SKET	LNPA_0118G-4 5	SK2021012102	2022/03/11

5. Test Conditions and Results

5.1. Disturbance voltage at mains terminals

Test requirement	FCC 47 CFR Part 15 Subpart B		
Basic standard	ANSI C63.4: 2014		
Test frequency range..	150 kHz to 30 MHz		
Limits.....	Limits for Class A		
	Frequency (MHz)	dBμV Quasi-peak	dBμV Average
	0.15 to 0.5	79	66
	0.5 to 30	73	60
	Limits for Class B		
	Frequency (MHz)	dBμV Quasi-peak	dBμV Average
	0.15 to 0.5	66 to 56	56 to 46
	0.5 to 5	56	46
	5 to 30	60	50
	Test method	The AMN placed 0.8 m from the boundary of the unit under test and bonded to a ground reference plane. This distance was between the closest points of the AMN and the EUT. All other units of the EUT and associated equipment were at least 0.8 m from the AMN. All power was connected to the system through Artificial Mains Network (AMN).	
Ambient temperature..	19.4 °C		
Relative humidity	46 %		
Test location	TCT Testing Industrial Park Fuqiao 5th Industrial Zone, Fuhai Street, Bao'an District Shenzhen, Guangdong, 518103, People's Republic of China		
Test model(s)	GP-1Li-FB-1S		
EUT operation mode..	Mode 1		
Test results	Pass		
Remark.....	/		

Measurement data and Graphical presentation of the result

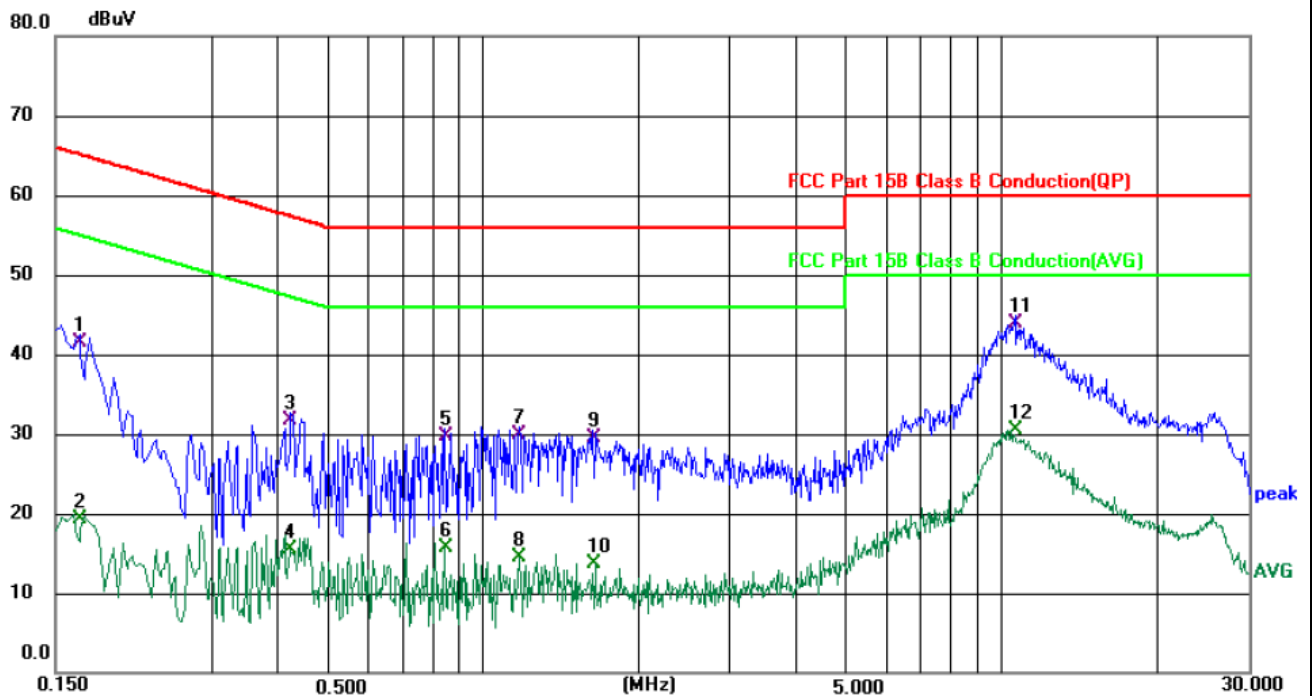

Site 844 Shielding Room

Phase: **L1**

Temperature: 19.4 (°C)

Humidity: 46 %

Limit: FCC Part 15B Class B Conduction(QP)

Power: AC 120 V/60 Hz

No.	Mk.	Freq. MHz	Reading Level dBuV	Correct Factor dB	Measure- ment dBuV	Limit dBuV	Over dB	Detector	Comment
1		0.1660	31.85	9.59	41.44	65.16	-23.72	QP	
2		0.1660	9.75	9.59	19.34	55.16	-35.82	AVG	
3		0.4259	22.41	9.22	31.63	57.33	-25.70	QP	
4		0.4259	6.28	9.22	15.50	47.33	-31.83	AVG	
5		0.8458	20.44	9.25	29.69	56.00	-26.31	QP	
6		0.8458	6.49	9.25	15.74	46.00	-30.26	AVG	
7		1.1778	20.50	9.35	29.85	56.00	-26.15	QP	
8		1.1778	5.24	9.35	14.59	46.00	-31.41	AVG	
9		1.6338	20.05	9.40	29.45	56.00	-26.55	QP	
10		1.6338	4.21	9.40	13.61	46.00	-32.39	AVG	
11	*	10.6340	34.33	9.61	43.94	60.00	-16.06	QP	
12		10.6340	20.93	9.61	30.54	50.00	-19.46	AVG	

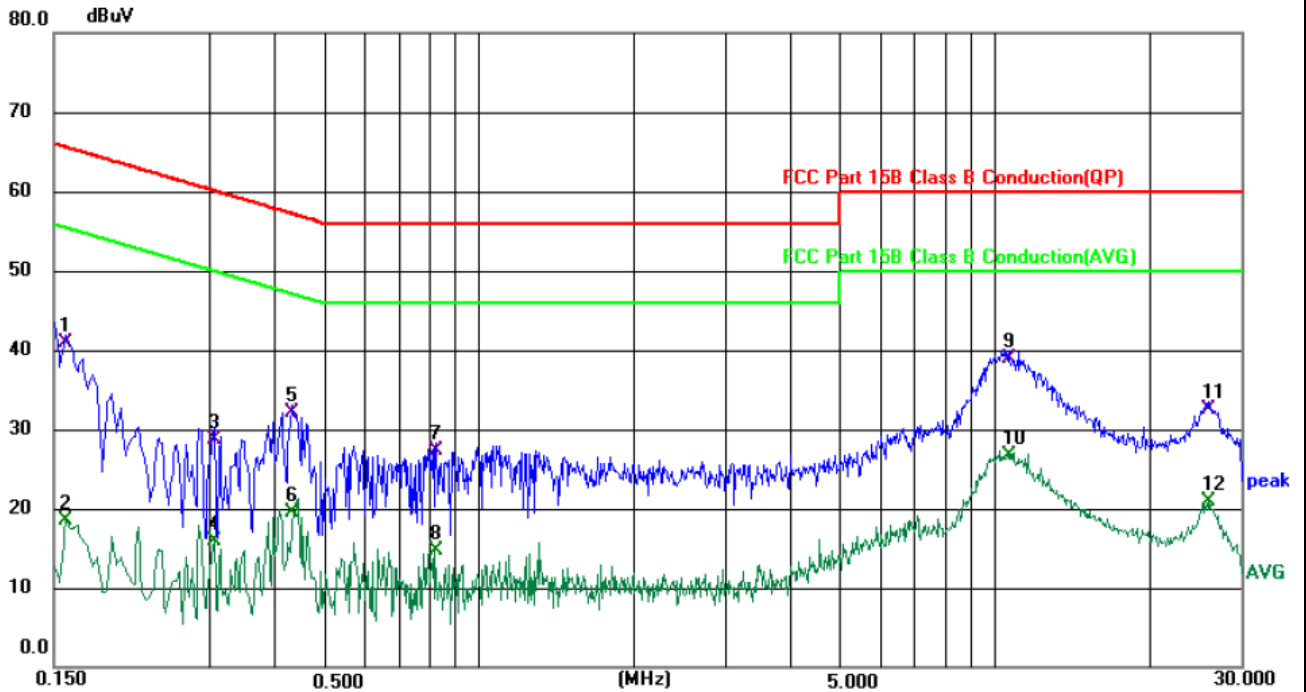

Site 844 Shielding Room

Phase: *N*

Temperature: 19.4 (°C)

Humidity: 46 %

Limit: FCC Part 15B Class B Conduction(QP)

Power: AC 120 V/60 Hz

No.	Mk.	Freq. MHz	Reading Level dBuV	Correct Factor dB	Measure- ment dBuV	Limit dBuV	Over dB	Detector	Comment
1		0.1580	31.30	9.59	40.89	65.57	-24.68	QP	
2		0.1580	8.89	9.59	18.48	55.57	-37.09	AVG	
3		0.3059	19.27	9.35	28.62	60.08	-31.46	QP	
4		0.3059	6.50	9.35	15.85	50.08	-34.23	AVG	
5		0.4339	22.79	9.24	32.03	57.18	-25.15	QP	
6		0.4339	10.24	9.24	19.48	47.18	-27.70	AVG	
7		0.8300	18.12	9.25	27.37	56.00	-28.63	QP	
8		0.8300	5.53	9.25	14.78	46.00	-31.22	AVG	
9	*	10.6220	29.37	9.62	38.99	60.00	-21.01	QP	
10		10.6220	17.18	9.62	26.80	50.00	-23.20	AVG	
11		26.0900	22.76	9.83	32.59	60.00	-27.41	QP	
12		26.0900	11.15	9.83	20.98	50.00	-29.02	AVG	

5.2. Radiated emission

Test requirement	FCC 47 CFR Part 15 Subpart B				
Basic standard	ANSI C63.4: 2014				
Test frequency range..:	30 MHz to 40 GHz				
Limits.....	Frequency (MHz)	3 m measurement distance			
		Quasi-peak (dBμV/m)			
		Class A	Class B		
	30 to 88	49	40		
	88 to 216	53.5	43.5		
	216 to 960	56.4	46		
	960 to 1000	59.5	54		
	Frequency (MHz)	3 m measurement distance			
		Class A		Class B	
		Peak (dBμV/m)	Average (dBμV/m)	Peak (dBμV/m)	Average (dBμV/m)
Above 1000	79.5	59.5	74	54	
Test method.....	Measurements were made in a 3-meter semi-anechoic chamber that complies to CISPR 16. Preliminary (peak) measurements were performed at an antenna to EUT separation distance of 3 meters with the receive antenna located at 1 to 4-meter height in both horizontal and vertical polarities. Final measurements (quasi-peak) were then performed by rotating the EUT 360° and adjusting the receive antenna height from 1 to 4-meters. All frequencies were investigated in both horizontal and vertical antenna polarity, where applicable.				
Ambient temperature.:	24.9 °C				
Relative humidity	51 %				
Test location	TCT Testing Industrial Park Fujiao 5th Industrial Zone, Fuhai Street, Bao'an District Shenzhen, Guangdong, 518103, People's Republic of China				
Test model(s)	GP-1Li-FB-1S				
EUT operation mode..:	Mode 2				
Test results	Pass				
Remark.....	/				

Measurement data and Graphical presentation of the result

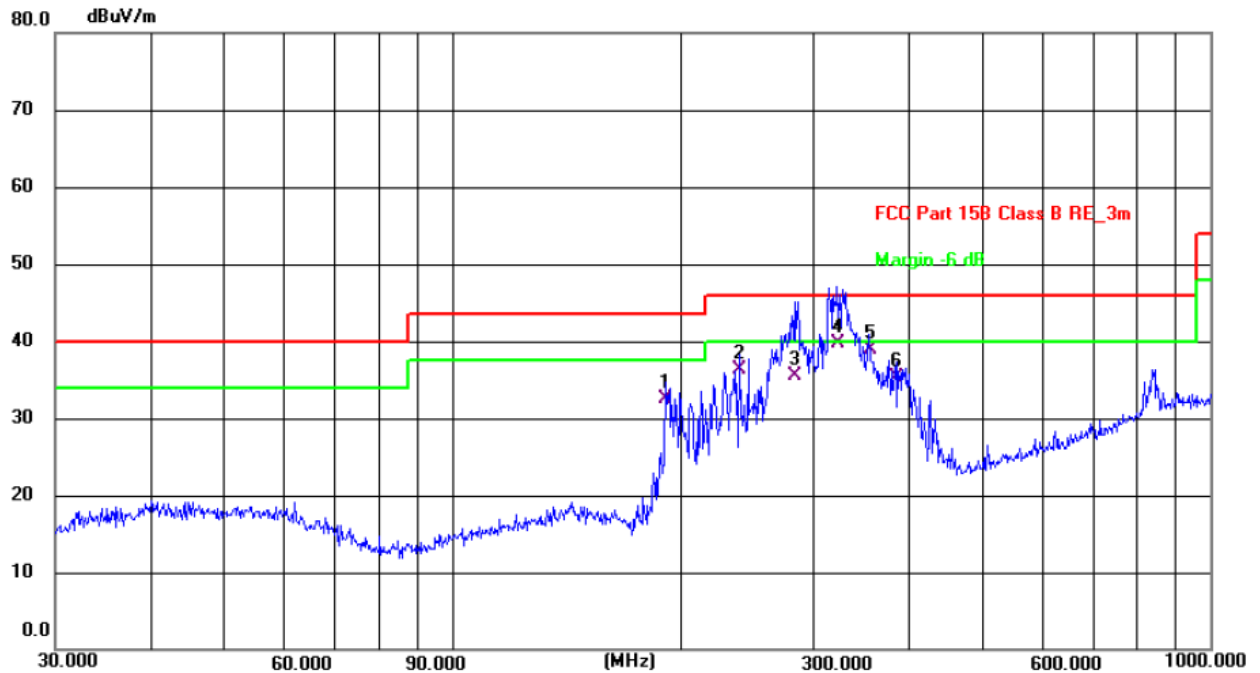

Site #2 3m Anechoic Chamber

Polarization: *Horizontal*

Temperature: 24.9(C) Humidity: 51 %

Limit: FCC Part 15B Class B RE_3m

Power: DC 14.8 V

No.	Frequency (MHz)	Reading (dBuV)	Factor (dB/m)	Level (dBuV/m)	Limit (dBuV/m)	Margin (dB)	Detector	P/F	Remark
1	191.0738	21.87	10.73	32.60	43.50	-10.90	QP	P	
2	239.1473	23.68	12.72	36.40	46.00	-9.60	QP	P	
3	282.9852	21.37	14.13	35.50	46.00	-10.50	QP	P	
4 *	322.1886	25.28	14.52	39.80	46.00	-6.20	QP	P	
5	355.4273	23.21	15.69	38.90	46.00	-7.10	QP	P	
6	385.2805	18.56	16.74	35.30	46.00	-10.70	QP	P	

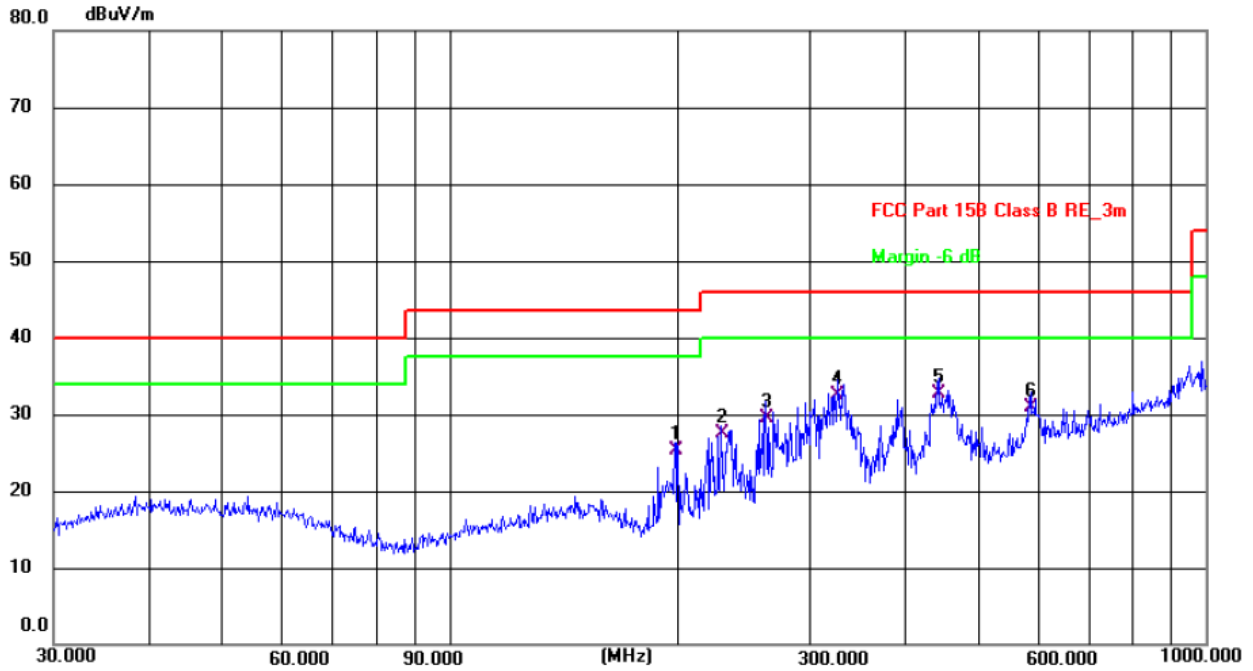

Site #2 3m Anechoic Chamber

Polarization: *Vertical*

Temperature: 24.9(C) Humidity: 51 %

Limit: FCC Part 15B Class B RE_3m

Power: DC 14.8 V

No.	Frequency (MHz)	Reading (dBuV)	Factor (dB/m)	Level (dBuV/m)	Limit (dBuV/m)	Margin (dB)	Detector	P/F	Remark
1	199.2855	15.08	10.32	25.40	43.50	-18.10	QP	P	
2	228.4904	15.60	12.00	27.60	46.00	-18.40	QP	P	
3	261.9753	16.90	12.70	29.60	46.00	-16.40	QP	P	
4	325.5958	17.96	14.64	32.60	46.00	-13.40	QP	P	
5 *	443.2943	14.62	18.18	32.80	46.00	-13.20	QP	P	
6	586.8437	9.88	21.02	30.90	46.00	-15.10	QP	P	



6. Test set-up photo

Disturbance voltage at the mains terminals Test View

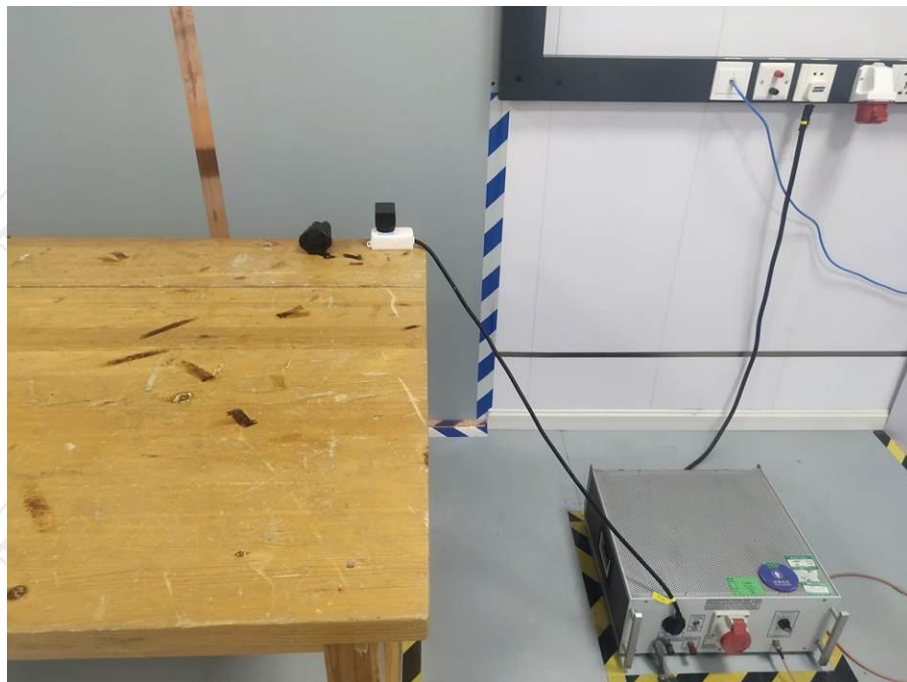

Radiated emission (30 MHz to 1 GHz) Test View

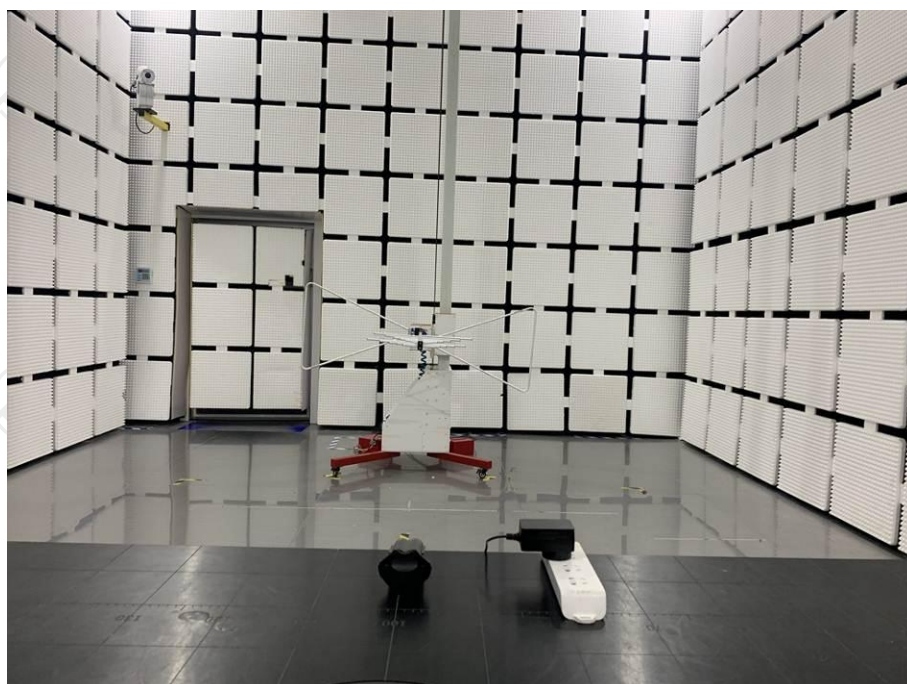

7. Photo of the EUT









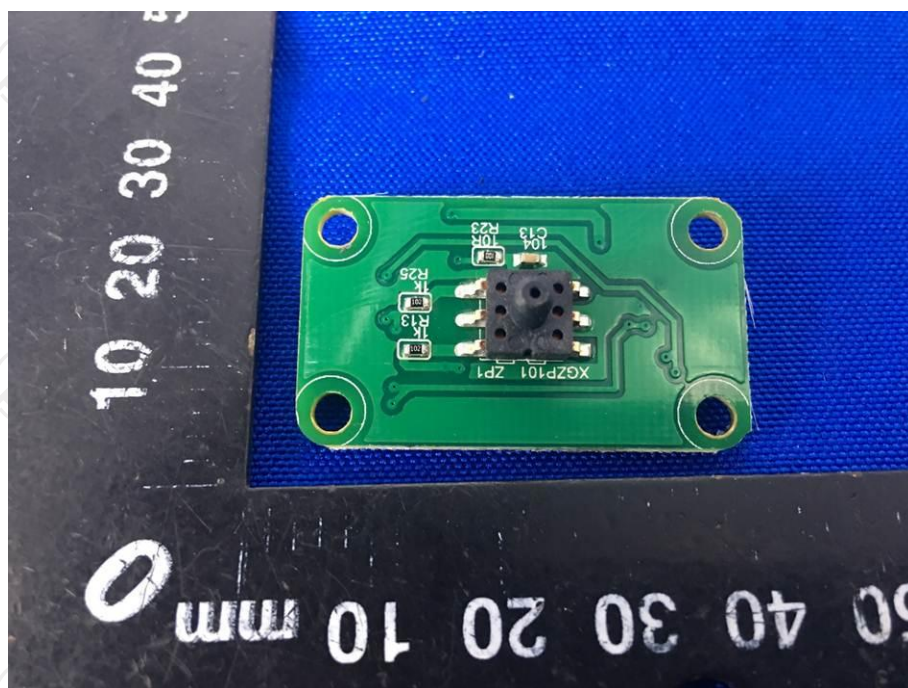
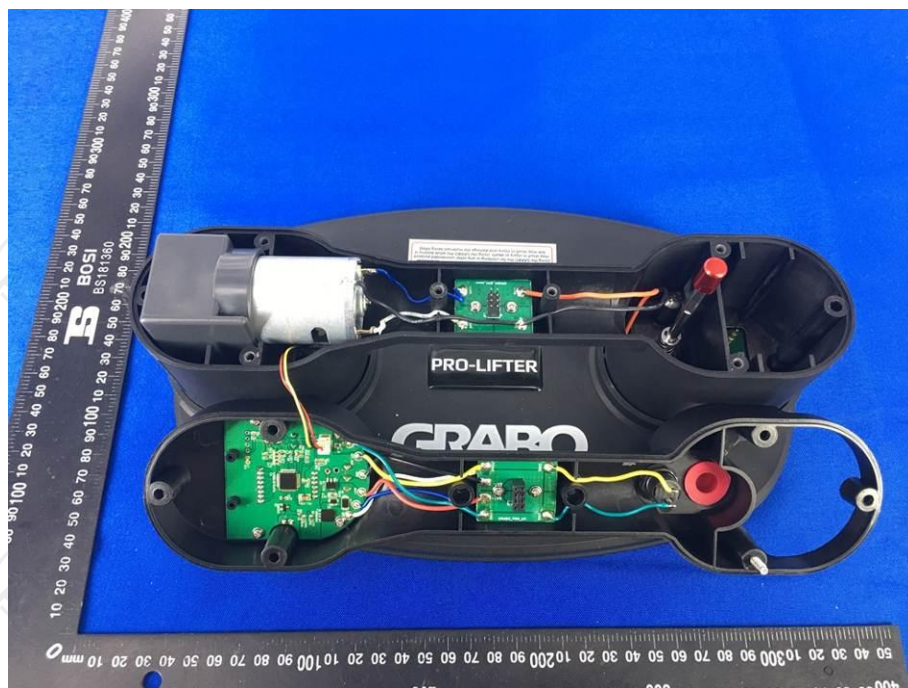

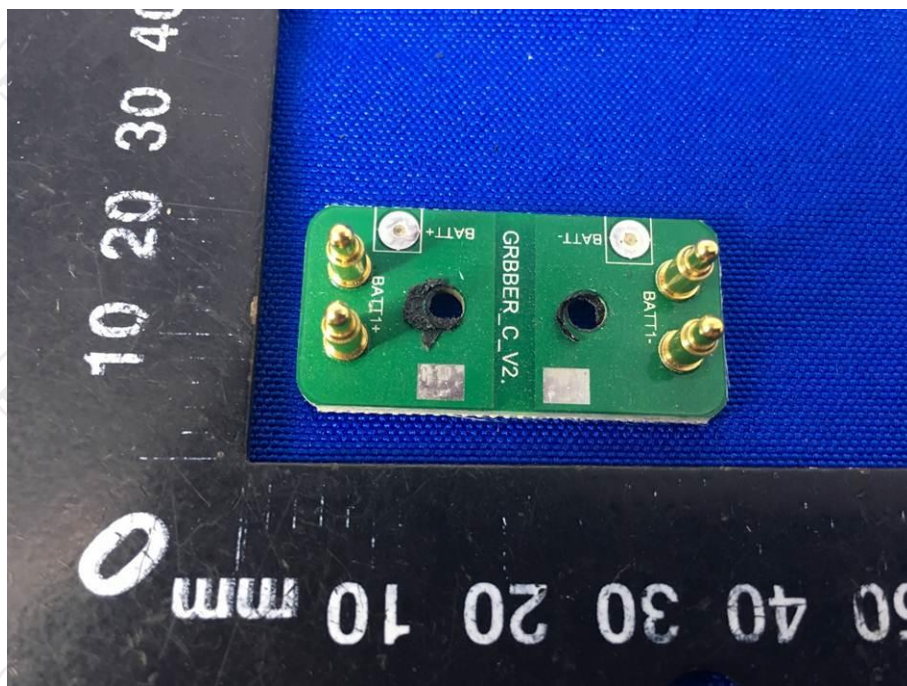
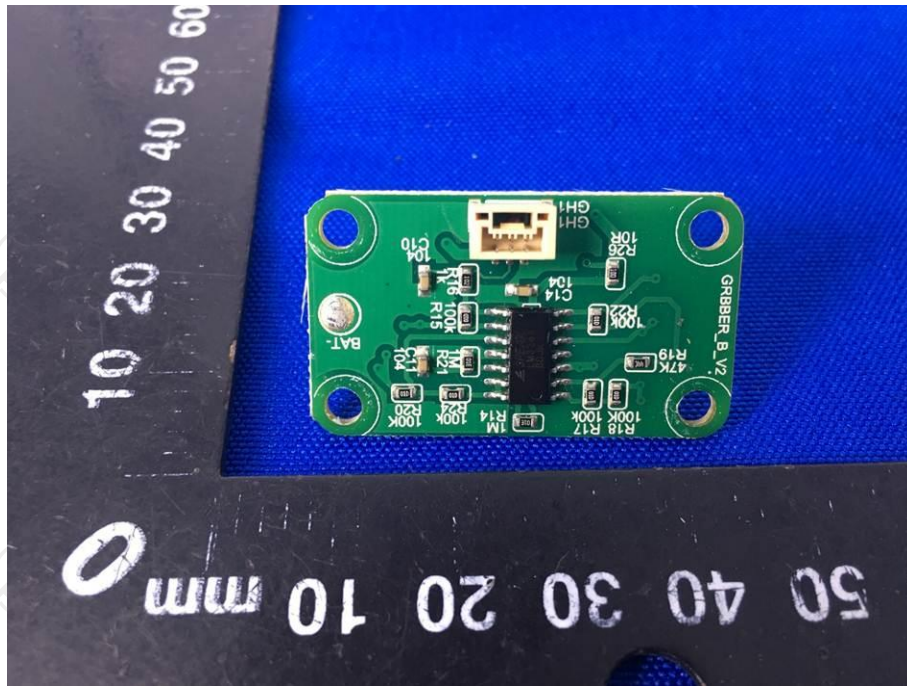

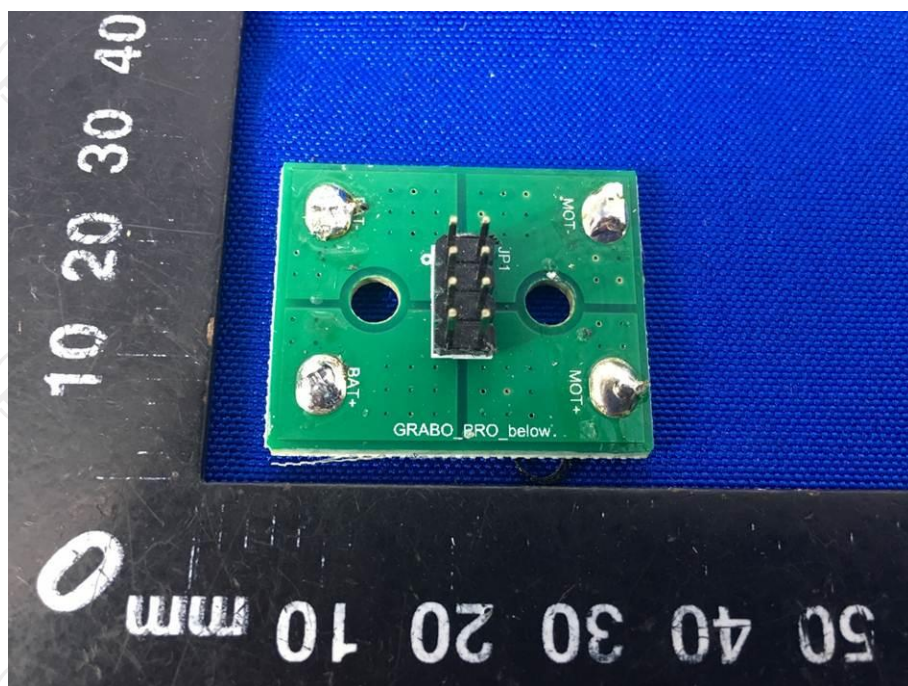
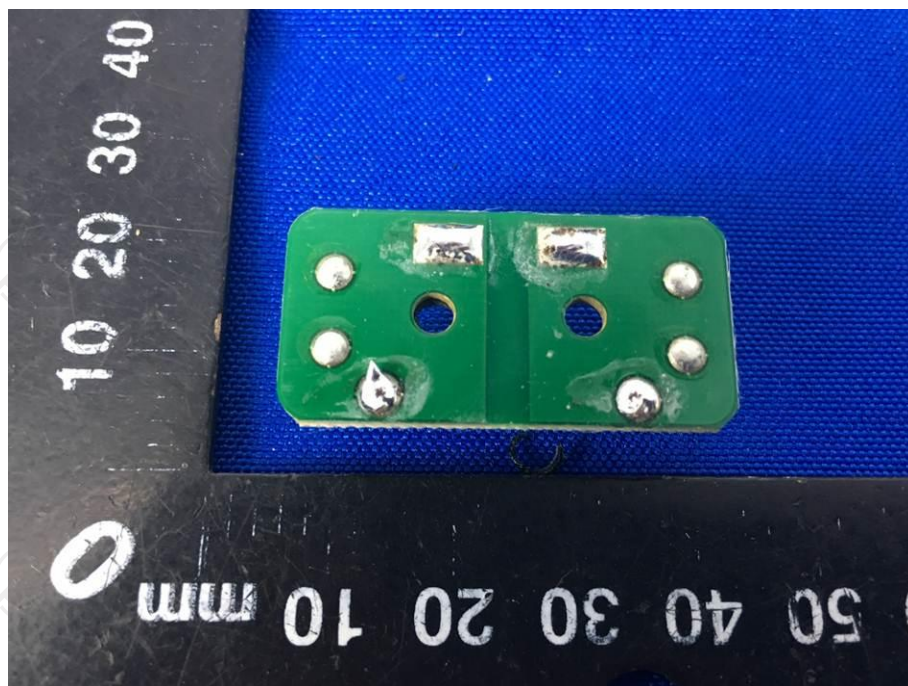

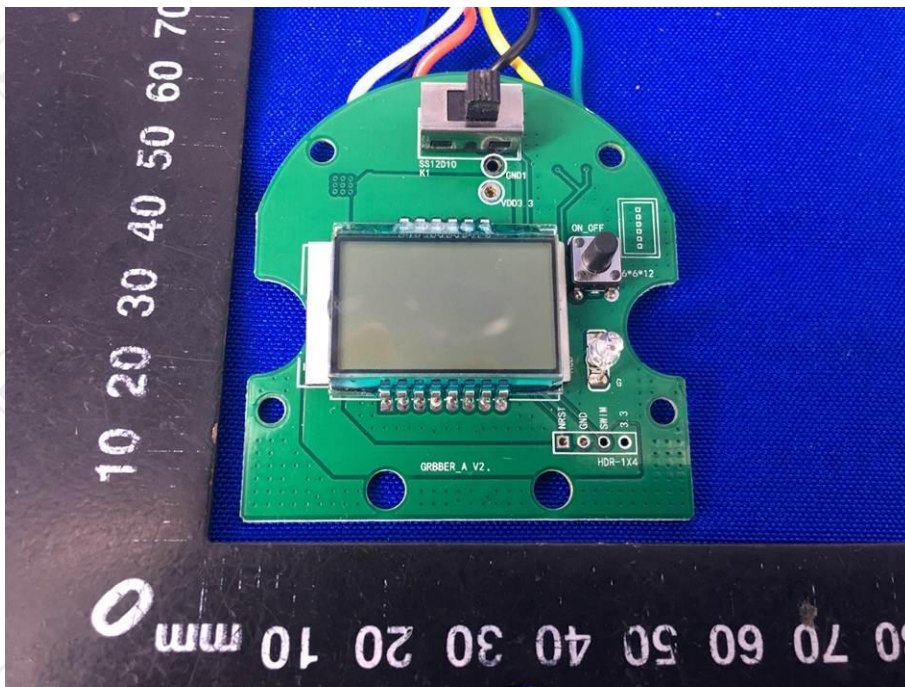
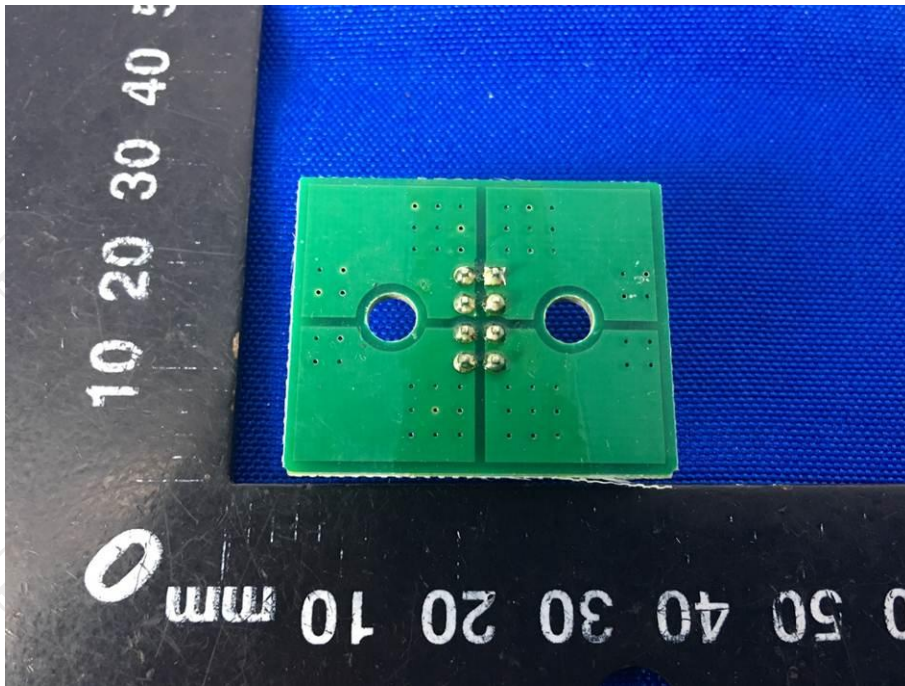

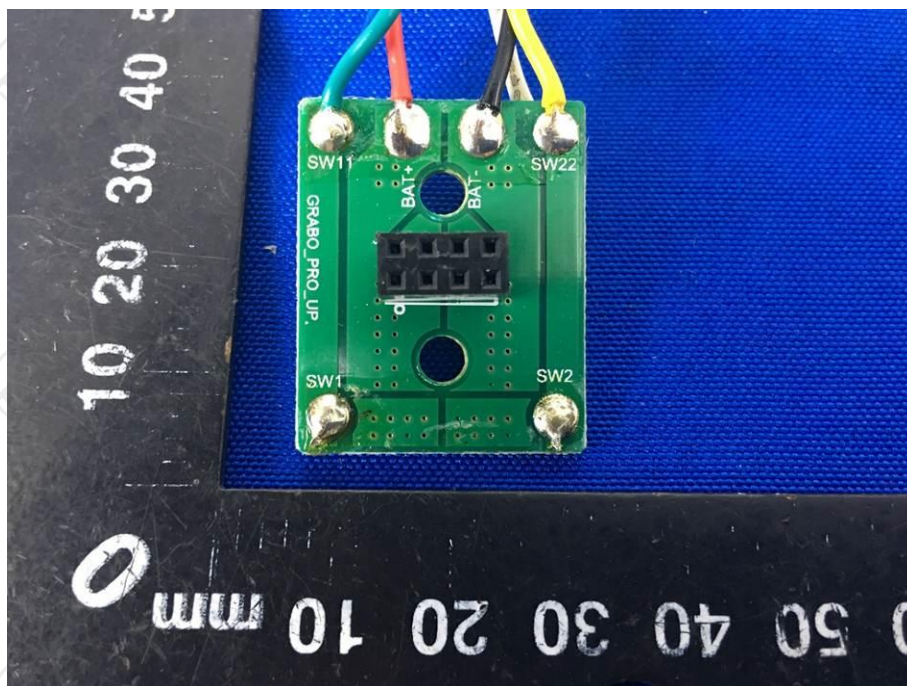

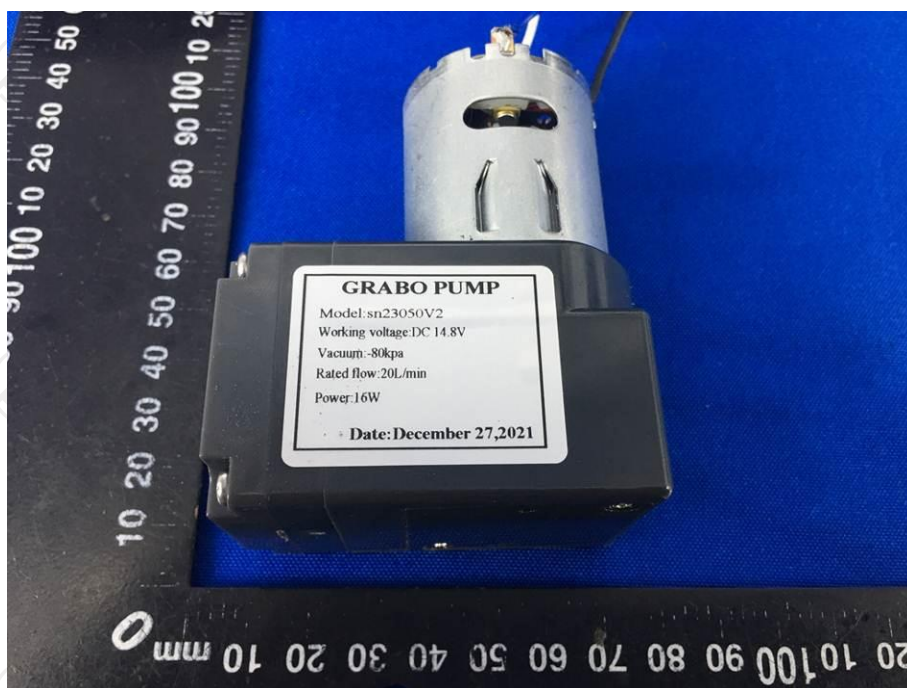
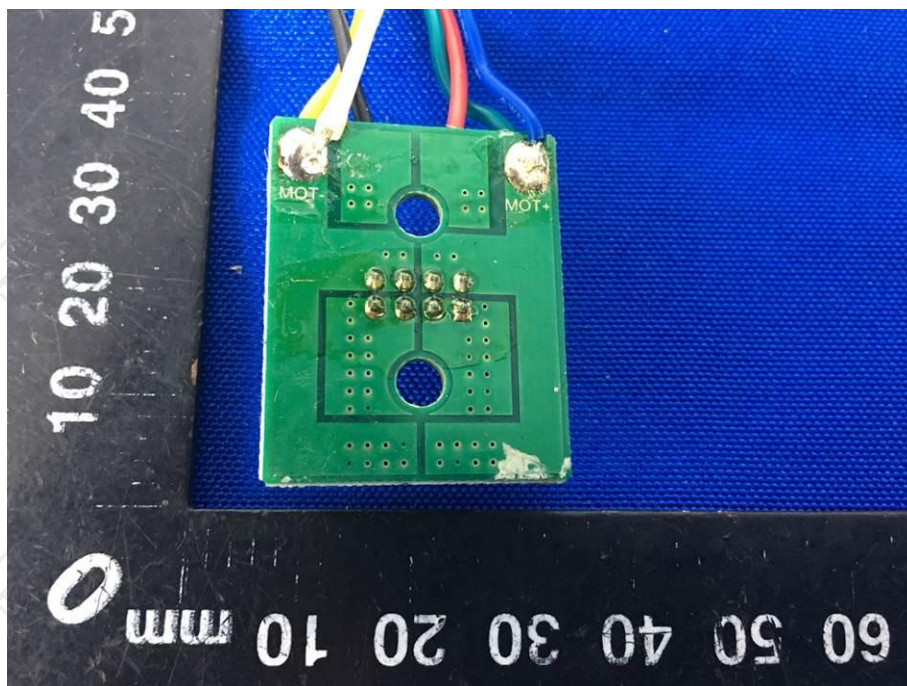



*******End of report*******